



Helmer Scientific, Noblesville, Indiana
www.helmerinc.com

Technical Data Sheet High-Performance, Platelet Incubator Model: PC4200-Pro

Application, Rating, & Electrical Data	
Application	Provides the controlled temperature environment and continuous gentle agitation conditions required for the storage of platelet products.
Storage Volume	384 WBD/ Random Bags 128 SDP/Apheresis Bags
Set Point Temperature Range	+20°C to +24°C
Set Point (default)	+22°C
Electrical Power	100-115V 50/60Hz 220-240V 50/60Hz
Maximum Current	3.1A 2.4A
Touch Current	≤ 3.5mA
Facility Supply Rating	Branch circuit with earth ground, meeting plug/cord ratings as well as local electrical safety codes and requirements 110-120V AC: 15 A (minimum) 220-240V AC: 10 A (minimum)
Power Plug/Power Cord Length	NEMA 5-15 hospital-grade 115V 60Hz, 8 to 10 ft (2.4-3.0m) Inquire about additional cord/plug options
Certification/Agency Listing	QPS (Certified to UL and CSA Standards) CB Test Certificate IEC/UL61010-2-011:2016 IEC 61010-1:2010, AMD1:2016 (220-240V)
Indoor/Outdoor Use	Indoor use only, non-residential
Application Environment	Non-corrosive, non-flammable, non-explosive
Ambient Operating Temperature	+15°C to +35°C +59°F to +95°F
Refrigeration System	
Refrigeration System	VCC compressor-based, forced-air hydrocarbon
Compressor	Hermetic, variable capacity (VCC). Rated speed range: 1300-4000 rpm
Condenser Type	Air-cooled fin and tube, sealed
Expansion Device	Cap tube
Evaporator Type	Direct expansion with forced-air fin and tube
Refrigerant	R600a, Isobutane, EU F-Gas and EPA SNAP compliant
Controller Configuration Settings	
User Interface	i.Center® Plus color touchscreen, 5 in 127mm screen, full color, °C or °F
Power Switch	On/Off
Controller Type	Microprocessor with touchscreen input & display
Security	Password protected settings
Controller Sensor	NTC, stainless steel
Communication Ports	USB, Remote alarm contacts, RJ45 (Ethernet), API available for Ethernet connectivity development.
Power Failure Alarm	Yes
High / Low Alarms - Tests	Yes, fully adjustable, automatic (Peltier) testing
Door Ajar Alarm	Yes, fully adjustable
Download	Yes, download via USB or Ethernet (API); XLS, TXT and PDF reports
On-demand Reports	Yes, Event log, Temperature log and other summary reports
Interactive Temperature Graph	Yes
AgITrak™ System	Yes, Provides control, monitoring, and reporting for built-in agitator
Chart Recorder	Yes, integrated, 4" (102mm) diameter, inkless pressure-sensitive charts, backup battery
Temperature Monitoring	Yes, Peltier primary monitoring probe. Pre-calibrated replacement available
Battery Back-up	Yes, minimum of 24 hrs display and alarm back-up for i.Center® Plus touchscreen monitoring rechargeable 12V, sealed lead acid
Agitator System	
Agitation Control	Yes, Auto start/stop with door opening, agitation on/off
Agitation Speed	62 ± 2, user adjustable through hardware setting
Trolley Throw	1.5 in
Motor	AC motor, 3-phase, with variable speed drive and gentle glide operation

Performance Characteristics	
Uniformity °C	±1°C
Energy Consumption kWh/day	4.9
Heat Rejection / Emission BTU/hr	683
Noise emission dBA	58

All performance data stated for Incubator with agitator running inside 62 cpm, at +22°C Set point in +25°C ambient conditions.

Dimensions and Construction	
Interior (w x h x d)	37.8 x 50.6 x 18.9 in 961 x 1286 x 480 mm
Exterior (w x h x d)	40.1 x 75.6 x 28 in 1018 x 1920 x 710 mm
Overall Exterior (w x h x d)	40.1 x 75.6 x 33.4 in 1018 x 1920 x 847 mm
Insulation	Rigid foam board Non-CFC, non-HFC, non-HCFC, environmentally friendly U.S. EPA SNAP compliant
Exterior / Interior Finish	Bacteria-resistant powder coating
Interior Storage	32 ventilated drawers Bacteria-resistant, powder coated galvanized steel
Drawer (w x h x d)	29.8 x 0.9 x 15.1 in 759 x 22 x 385
Drawer Spacing	Adjustable, 0.7 inch increments
Door	2, hinged, dual-pane tempered glass, with key locks
Access Port	Yes, 0.75 in (19mm) diameter
Casters	Yes, swivel-locking
Net Weight	740 lb 336 kg (100-115V) 743 lb 337 kg (220-240V)
Shipping Weight	863 lb 391 kg
Clearance Requirements	Minimum 4 in 102 mm above unit Minimum 4 in 102 mm behind unit for clearance and feature access Additional clearance required +28°C ambient and above
Options Accessories	Secondary Monitor Probe, Protective Shelf Guards and Dividers, USB Flashdrive, Floor and Wall bracket kit, Additional cord/plugs, Remote Alarms, Chart Paper, Certificate of Calibration, Temperature Validation, Extended Warranty
Warranty	Rel.i™ Warranty- 5 years compressor, 2 years parts, 1 year labor Outside US and Canada- Contact your distributor for warranty information

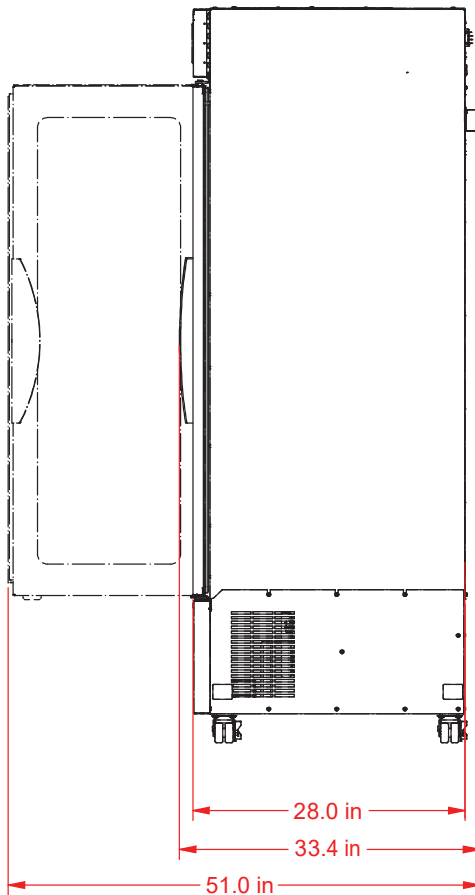

SIDE VIEW

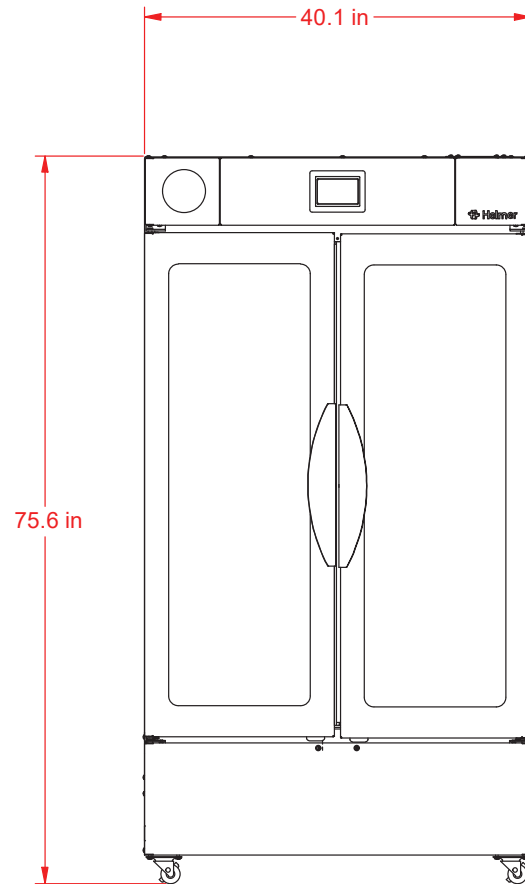

FRONT VIEW